

INSTRUCTION MANUAL

EDITION

Old editions (old format) ----- to 2006 04 11
 NEW manual format November 2006, SW-Version 3.00 ----- 2006 11 05
 2007 07 01
 SW-Version 3.04 ----- 2007 11 01

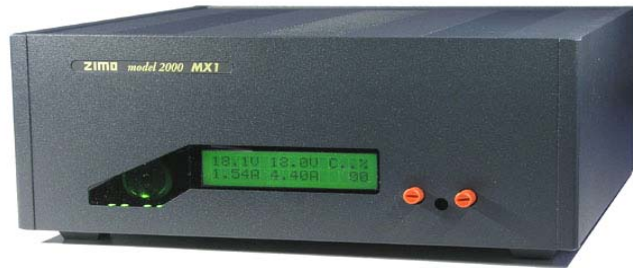

**STANDARD
MX1**

**HIGH OUTPUT
MX1HS**

**ECONOMY
MX1EC**

Chapter	
1. Introduction	2
2. Overview	2
3. Specifications	2
4. Power supply – external transformer	4
5. Connecting cabs (throttles)	4
6. Connecting the main and programming track	4
7. Controls and applications	5
8. The DIP switches (back of MX1)	6
9. The auxiliary inputs (Shuttle, AOS...)	7
10. The CONTROL bus (booster connection)	8
11. The Configuration Variables	9
12. MX1HS as Booster-Unit	11
13. Fuses	11
14. SOFTWARE Update	12
15. The Program ZST (ZIMO Service Tool)	12
16. AOS – Automatic Operating Sequences	13
17. The “old” (ASCII-oriented) Interface	15
18. The “new” binary Interface Protocol	18

IMPORTANT NOTES to SOFTWARE and SOFTWARE UPDATES:

Software that determines the characteristics and functions of this product is stored in a FLASH-EPROM.

Current software is available at no charge from www.zimo.at (UPDATES). The software can be installed with the help of the program “ZST” (Zimo Service Tool) but also at the DOS level with the program LOADHEX. The ZST program is available for download from the above web site at no charge.

Updates can also be performed by exchanging the EPROM with a new one from ZIMO for a minimum charge of EUR 10.00 to EUR 15.00 (handling and burning of the chip). An additional EUR 10.00 will be charged if the old EPROM is not sent back. More information at: www.zimo.at.

Some functions may depend on the software level of other components. It is therefore recommended to use matching software in the different ZIMO components.

ZIMO cannot guarantee that future functions (including the ones covered in this manual) will be implemented as planned or in the time frame suggested.

1. Introduction

The command station is the central processing unit of a DCC system (according to NMRA definition it is a combination of "command control station" and "power station").

The command station uses the CAN bus cable to communicate with the cabs and if applicable with accessory modules, track section modules and other modules.

The command station sends stabilized and short circuit protected power to the track, which also includes the control information for locomotive and accessory decoders in the standardized NMRA-DCC format, the MOTOROLA data format or both (see below).

Control information and data formats . . .

"Data format" indicates the kind of data transmission used to send information from control units (command stations, cabs...) to mobile decoders in locomotives or fixed decoders for switches or signals. The following data formats are relevant:

DCC (Digital Command Control): this is a data format standardized by the **NMRA** (National Model Railroad Association) and is also used by DCC systems and decoders of other manufacturers like Lenz, ROCO, LGB, Digitrax, NCE and others.

MOTOROLA: A data format used by Märklin under the name "Märklin digital", "Delta" as well as Märklin's own new "mfx". All recently produced Märklin locomotives come with an appropriate decoder installed. Decoders operating with the MOTOROLA format can be controlled with a ZIMO system and, if required, simultaneously with DCC decoders.

Each data format can be selected with switches marked „DCC“ and "MOT" on the back side of the command station. The version MX1EC is equipped with jumpers instead of switches. All command stations are **delivered with the DCC mode** enabled and the MOT disabled.

It is recommended to enable only the data format that is actually being used! This improves the data flow to the track: data for each engine is sent faster and repeated more often. Disabling the DCC format in a MOTOROLA only set-up simplifies the handling and control: locomotive and turnout addresses can be entered in the cab without a prefix.

2. Overview

The command station is available in 3 versions...

<p>MX1 The standard command station</p>	<p>Up to 8A of track power; separate outputs for main and programming track (may be part of layout). 2 CAN bus sockets, RS232 interface, 8 inputs for automated shuttle operations, AOS events, external panic button, 4-pin control bus socket for the control and feedback of external boosters (other brands are also suitable). 2-line LCD display (2 x 16 characters) for the display of volt and amp readings for both track outputs as well as CAN bus activity, error messages, programming and AOS information and more.</p>
<p>MX1HS The high-output command station</p>	<p>Up to 2 x 8A of track power at two equal track outputs, independently adjustable track voltage, parallel connection of both track outputs is possible (16A); one output may serve the programming track. Otherwise identical to MX1 with the same software; configurable with jumpers for the use as a large booster MXBOO (as slave unit of another command station with 2 x 8A).</p>
<p>MX1EC The economy command station</p>	<p>Identical to the MX1 in terms of power (8A track power), processor and memory capacity as well as software. Priced lower due to a simpler logging, simpler connections, LED chain instead of an LCD display for volt and amp indications (an external 2 x 16 display is available as an accessory). Only one track output, which is used for the main or programming track.</p>

3. Specifications

Transformer input: maximum voltage (-)	28 V
Track outputs, adjustable power (***)	12 to 24 V
Main track output ("SCHIENE 1", max. power **)	8 - 10 A (***)
Programming track output of the MX1 ("PROGRAMMIERGLEIS") max. power	3 A
Programming track output of the MX1HS ("SCHIENE 2"), max. power	8 A
Dimensions MX1, MX1HS (B x H x T, incl. rubber feet)	210 x 90 x 210 mm
Dimensions MX1EC (B x H x T, incl. rubber feet)	210 x 60 x 210 mm
Weight	1.5 kg (MX1) , 2 kg (MX1HS) , 1 kg (MX1EC)

*) In accordance with consumer protection laws, a maximum of 24V is allowed for toy applications; ZIMO products are however not declared as toys and the command station can operate with up to 28V transformer input.

**) When using a transformer with a secondary output of 25V (i.e. ZIMO TRAF025), the maximum track current of 8A is only available at a track voltage setting of no more than 20V. Track power (current) will be less with track voltages above 20V. If a 28V transformer is used it is possible to get 8A to the track even with the track voltage set to 24V.

***) ATTENTION: It is important to adhere to the allowable track voltage specified for the decoders in use, especially when using third party decoders!

COMMAND STATION MX1 or MX1HS - FRONT VIEW

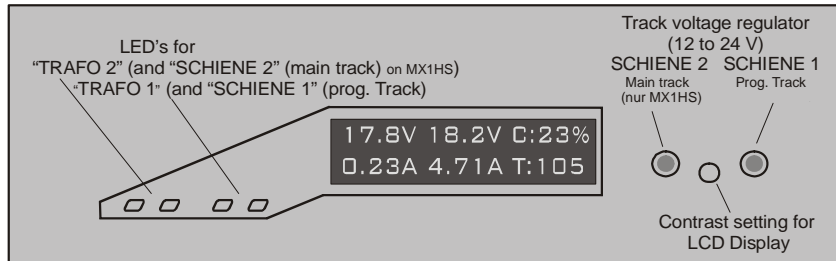

COMMAND STATION MX1EC - FRONT VIEW

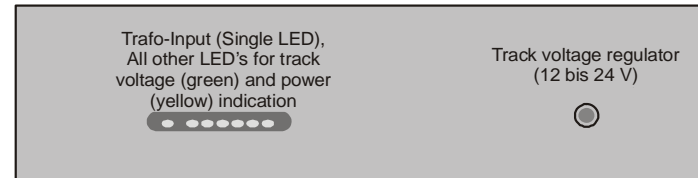

COMMAND STATION MX1 - BACK VIEW

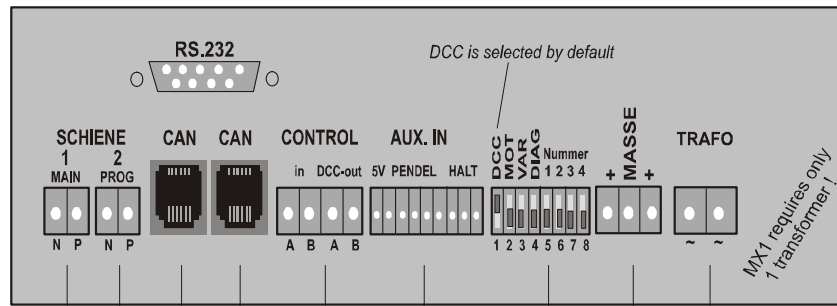

COMMAND STATION MX1EC - BACK VIEW

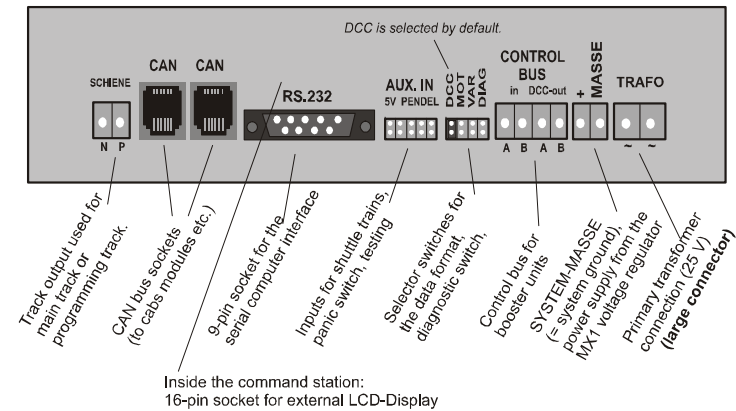

COMMAND STATION MX1HS - BACK VIEW

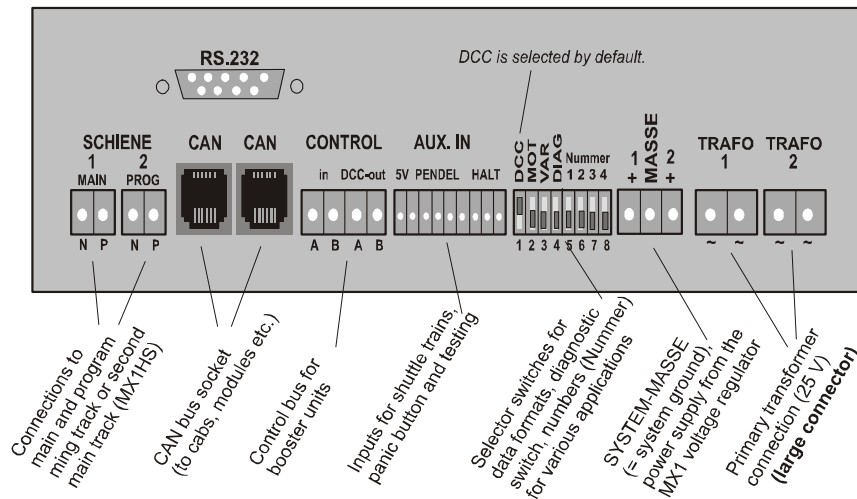

4. Power supply – external transformer

ZIMO command stations do not have a built-in transformer. An external transformer must be connected to the “TRAFO” terminal on the back panel. In order to fulfill local regulations use only approved transformers (i.e. UL or other applicable agencies).

The requirements for the transformer (or the two transformers in the case of the MX1HS) as the primary power supply are:

Rated output 24 to 28V, nominal power at least 50VA, preferably 100 to 200VA.

Commercially available model railroad transformers (or power packs) are not suitable because the voltage is not only too low but are also affected by load; they are usually not powerful enough either. Transformers of up to 28V are recommended for large-scale applications if track voltage of more than 20V is required!

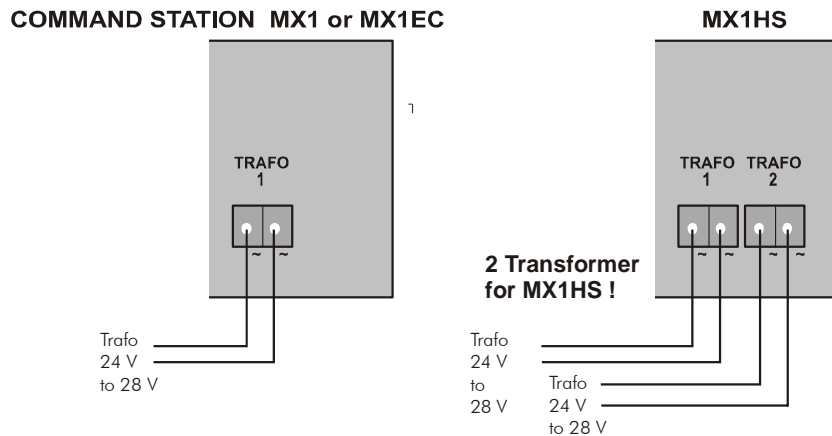

Note to the „CAN bus“ (Cable from command station to cabs and other modules) . . .

Ready made CAN bus cables can be obtained from ZIMO in standard and custom length (see price list) but can also be made by the end user; the required 6-conductor cable, connectors (package of 50) and the special mounting pliers are also available from ZIMO.

Connecting several cabs to the CAN bus is in most applications problem free (up to 10 cabs or other modules on the bus. With up to 50m total cable length and no more than 2 cabs at the end of the 50m cable, or no more than 5 at the end of a 20m cable)

If the number of cabs or the distance to the command station is higher, some threshold values and countermeasures need to be considered (terminating resistors, typically 150 to 330 Ohm between the center pins of the CAN bus connector of the farthest module, contact ZIMO if needed!).

5. Connecting cabs (throttles)

All ZIMO command stations come equipped with two identical 6-pin RJ-12 **CAN bus** sockets (internally connected) that accepts 6-conductor can bus cables, which are used for the data transfer between the command station and cabs as well as other ZIMO products (accessory modules, track section modules etc.).

Every ZIMO cab also contains the two CAN bus sockets so that all cabs may be daisy-chained without the use of any special distribution boxes.

Instead of connecting all cabs with each other (daisy-chain), a 6-conductor bus cable can be installed on the layout with appropriate distribution boxes to which cabs can be connected where needed.

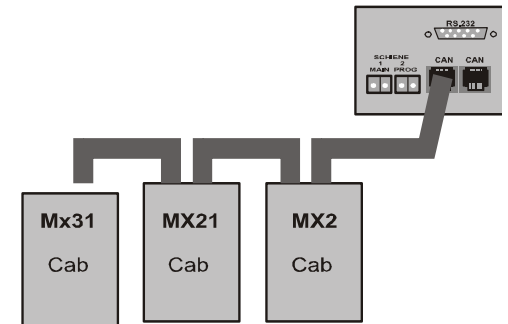

6. Connecting the main and programming track

... to the standard command station MX1 ...

The MX1 command station is equipped with two track output sockets.

- the **output “MAIN”**, to which the main track of the layout is connected to. This output is rated at the full 8A.
- the **output “PROG”**, to which a section of track, isolated at both ends from the rest of the layout track, is connected that serves as the programming track for programming loco addresses (and CV's) of locos equipped with a DCC decoder. This could be a ZIMO decoder or decoders from other manufacturers such as Lenz, Roco etc. This output is limited to 3A. Exceeding this limit turns the power to this output off and is shown in the MX1 display with “UEP” - as opposed to “UES” after the main track output is turned off.

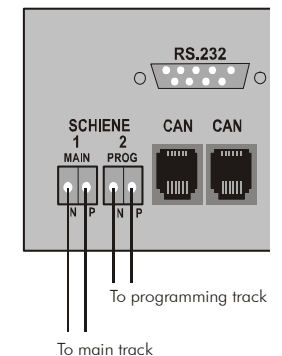

If no programming procedure is running, the programming track may be part of the layout and used in the same way. Naturally, power on that track section is always limited to 3A. With the help of the DIP switches on the back side of the command station the power can be further reduced (down to 1A or even no load), which can be useful when testing a newly installed decoder to reduce the risk of damage to the decoder in case of wiring errors.

If the programming track is part of the layout (main track), which allows locomotives to be driven on and off the programming track (with both rails isolated), the polarity of the two has to be the same for both (pin N, pin P)!

... to the high-output command station MX1HS ...

The MX1HS is equipped with **two 8A rated outputs** marked SCHIENE 1 and SCHIENE 2, whereas the output SCHIENE 2 also functions as the programming output "PROG" as soon as a programming procedure is started with the cab or the computer.

Therefore, before any "service mode" programming procedures is started with a MX1HS command station, the main track must be removed from the output "SCHIENE 2 = PROG" and the programming track connected instead!

ATTENTION: Before proceeding with programming a locomotive, make sure that the programming track is the only track connected to the output SCHIENE 2 = PROG. If any part of the main track remains connected, all locomotives on that track will also be re-programmed!

The two outputs SCHIENE1 and SCHIENE 2 (except during programming) supply power to two power districts of a layout. They can also be wired in parallel to create one powerful district.

ATTENTION: Do not wire the two MX1HS outputs in parallel when track section modules MX9 are in use on the layout!!

... to the economy command station MX1EC ...

The MX1EC has only **one track output**, which can be used for either the main track or the programming track.

ATTENTION: With an MX1EC the main track must be disconnected and the programming track connected in its place, before any "service mode" programming procedure is started (with the cab or a computer)! This can be accomplished with an external switch or by switching the track connectors on the MX1EC.

If the main track remains connected by mistake during a programming procedure, all locomotive and accessory decoders will also be re-programmed!!

Possible protection procedure: See CV's #31 - 38, "Enable programming"!

The track polarity is normally of no importance, except when track section modules MX9 are employed. In such cases the rail that is to be cut for dividing the layout into sections must be connected to the track output pin "P" on the command station (via the MX9 in/outputs). The common (un-interrupted) rail must be connected to the "N" output pin.

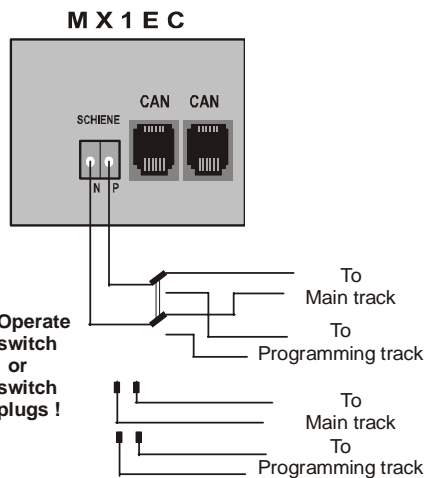
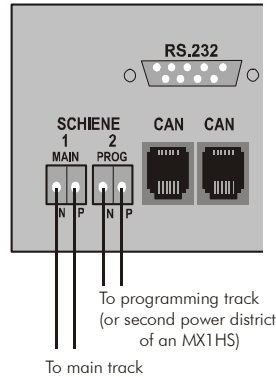

The diameter of the track supply wire must be adequate otherwise...

... speed and lights may fluctuate and in serious cases may lead to communications breakdown, but also...

... causes the wiring to overheat to the point that it could catch fire, especially when outputs are wired in parallel (high currents)!

A wire diameter of at least 0.75 mm² (20 AWG) is recommended; 1.5 mm² (14AWG) is ideal for wires longer than 5m (15ft). Larger layouts should be fitted with several drop feeders (@ every 5m) to prevent noticeable voltage drops along the track.

7. Controls and applications

... on the standard command station MX1 and high-output MX1HS ...

After connecting a transformer to the input connector "TRAFO" (or two transformers on a MX1HS), three green LED's should light up (or four green LED's on the MX1HS).

At first, the display shows a start-up sequence (device type, software version and self test results depending on the DIAG switch position on the back of the MX1), after which the standard display shows track voltage and power of both track outputs (SCHIENE 1 and 2).

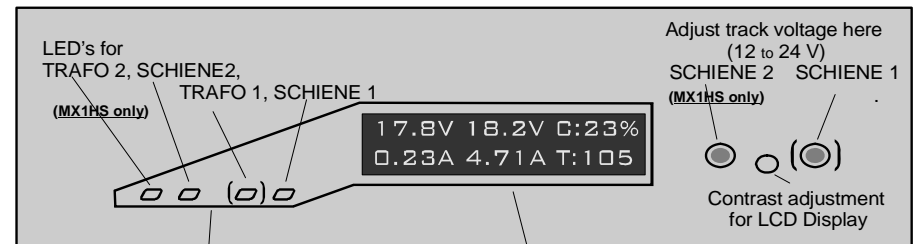

3 LED's on MX1, 4 LED's on MX1HS:
 LEDs (green) for "TRAFO" input indicate: adequate voltage from transformer (only one LED on Mx1 because only one transformer is connected; two LED's on MX1HS because two transformers are connected)
 LEDs for "SCHIENE" (by-color LED's, red/green)
green: Track power on
red: Track power off (Most often due to short circuit)

LCD Display:
 During power-up: Displays device type and the software-version; self-test messages.
 During normal operation: Volt and Amp reading of both track outputs or short circuit indication (UES, UEP), CAN bus load in % (C:), CAN bus error (E:).
 When "SL" is displayed: Command station operates as booster (slave) if all data format switches DCC, MOT, VAR are OFF.
 During decoder programming and read-outs (using the cab): Display of CV numbers and values (the MX1 display is easier to read than the MX2).
 During other definition events (e.g. Autonomous block control): Information help to support the operator.

... on the economy command station MX1EC ...
 (and connection of the external MX1DIS display)

The MX1EC does not have a built-in display like the standard MX1 command station does, but the same display is available as an external module (part # MX1DIS) that can be connected to the MX1EC. See below!

A built-in light bar (LED's) on the front of the MX1EC serves as a rough indicator for applied track voltage and power.

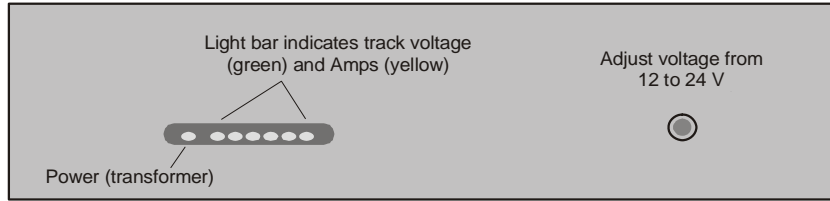

A green single LED in the light bar indicates track voltage in steps of 2V; The LED's switch to yellow and form a bar for track current indication (scale is not linear, with finer graduation in the lower range). The LED color changes to red just before reaching the maximum amperage (that is at 7A with the default setting).

Volt and Amps are indicated simultaneously whenever possible; the amp display will automatically fade out when changing track voltage. The last LED on the right lights up red in overload situations (short circuit on the track or input voltage from transformer too low).

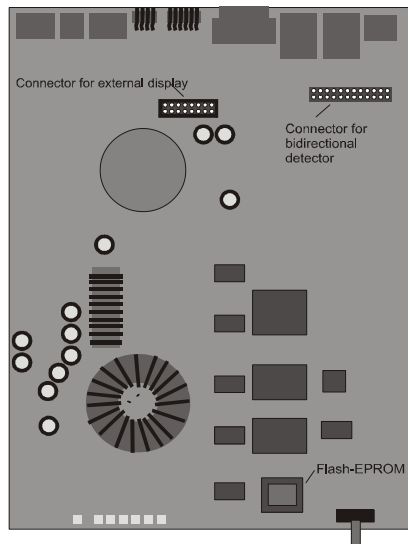
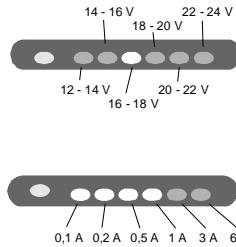

To connect an **external MX1DIS display module** proceed as follows:

Remove the screws on each side of the MX1EC and lift the top off the command station. Locate the 16-pin socket inside (see drawing at left) and plug in the cable that comes with the display module. Lead the cable to the outside above the RS232 connector on the back and reinstall the top.

The displayed information is largely identical to the built-in display of the MX1 (see above), but only shows one volt and amp meter since only one track output is present on the MX1EC.

8. The DIP switches (back of MX1)

... on the standard MX1 or high output MX1HS command station ...

The **data format switch DCC, MOT, VAR:**

The command station as delivered is set to operate in the DCC data format only. If required, the MOTOROLA mode can be selected instead or in addition to the DCC format.

The switch VAR is not used for now. It can be used in the future for selecting another data format or for the distinction of different variants of a given data format.

The **diagnostic switch DIAG:**

This switch (or jumper on the MX1EC) is for the planned actuation of a comprehensive self test at system start up (memory function, output tests via feedback wires etc.); will be implemented with a future software update.

The switch is also used for a general switch-over from the 8 to 12 function mode.

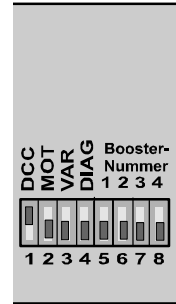

... on the economy command station MX1EC ...

The **data format jumpers DCC, MOT, VAR:**

The same meaning and functions apply as to the switches above; also set to the DCC format at delivery.



... on the high output command station MX1HS as booster ...

If all three data format switches **DCC, MOT and VAR are set to OFF**, the command station is in the booster mode (also known as slave unit), which means it will reproduce the control signals of another command station MX1, MX1HS or a compatible third party product once connected with them via the CONTROL wires (see chapter "The CONTROL bus"). This mode is indicated in the right margin of the display with "SL" (= SLAVE).

For the unit to function as a true booster (converting a MX1HS to a MXBOO) it is also necessary to change internal jumper positions; see chapter "MX1HS as booster unit"! If more than one booster is used set each booster to a unique number sequence with the dip switches 5 – 8 (this limits the number of boosters to 15).

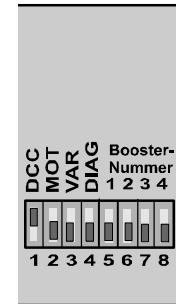

... The switches 5 - 8 on the MX1 or MX1HS ... (but not MX1EC) ...
 ON / OFF is marked on the DIP switch body

Switch 5 ON (turn ON briefly, then OFF): Clearing all priorities in the DCC queue - quicker reaction times by eliminating addresses which are no longer relevant.

Technical explanation: The command station continuously sends out commands to all 10239 addresses (send cycle); this is used to refresh the data in the loco decoders and allows the loco number recognition to function. The priority of each single address varies – highest prior-

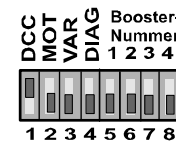

ity is given to recently changed data (when a cab was used), followed by active addresses (in the cab display), in the recall memory and so on all the way to addresses that were activated in the past and finally such that have never been used (lowest priority).

Switch 7 ON: Output "PROG" is limited to 1 A, normally it is limited to 3 A for MX1 and 8 A for MX1HS).

Switch 7 and 8 ON: Service mode programming is locked! Prevents start of the programming process by mistake; useful for MX1HS, where the PROG output is used alternatively as a normal track output ("SCHIENE 2").

Switch 8 ON: "PROG" output provides power to the track only during a programming procedure; driving on the programming track that is normally possible is locked; may be useful if unsure about the proper installation of a decoder – less chance of destroying the decoder.

All switches ON: Erases command station memory; useful if unexplainable malfunctions point to a possible messed up memory.

... If "old" ZIMO decoders operating in the 8-function mode are used ...
NOT RELEVANT FOR SYSTEMS AND DECODERS FROM 2003 AND UP

Until 2002 all ZIMO decoders were delivered in the 8-function mode. If these decoders cannot be set to the 12 function mode or that is not desired, the command station can be switched back to the 8-function mode (general switch-over of all addresses) as follows:

- >> Turn off the command station (unplug transformer from main); with the command station unplugged, place the DCC, MOT, VAR switches to OFF and the DIAG switch to ON (with a MX1EC pull the DCC, MOT, VAR jumpers and install the DIAG jumper).
- >> Turn on the command station (plug-in transformer); with the command station powered up: Bring the VAR switch or jumper in the desired position; the position the switch or jumper is left in determines the selected mode:
 OFF (or jumper pulled) = 8-function / ON (jumper installed) = 12-function mode.
- >> Power down the command station within 10 seconds, and then place all switches or jumpers to the normal position (i.e. DCC ON).
- >> Command station is ready to resume normal operation.

NOTE: A disagreement between the system and decoders regarding the 8- or 12-function mode is noticed by functions 5 – 8 not operational (not just functions 9 and up!) as well as the non-working MAN-Bit function!

The "general switch-over" to the (old) 8-function mode described above should only be used in exceptional cases; an address specific adjustment is the better choice (either in the decoder with CV #112 or the system through the cab).

9. The auxiliary inputs (Shuttle, AOS...)

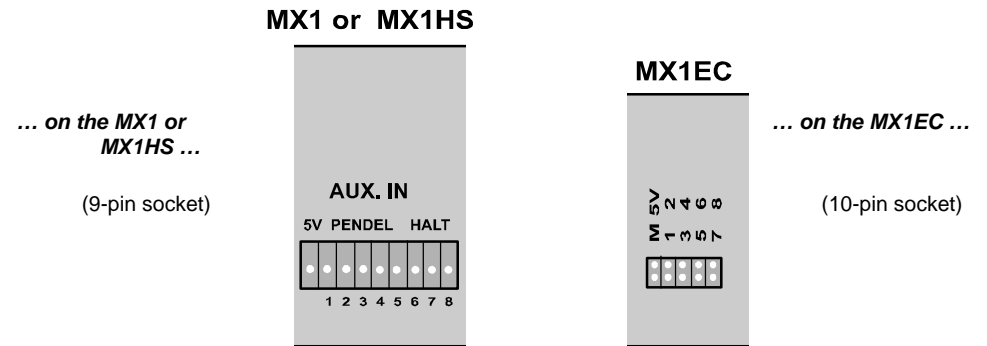

The command stations are equipped with 8 inputs that can be used with track switches or other external input components such as reed switches etc. One of the pins is a 5V output that can be used to supply external switches with the necessary voltage; however, any other positive voltage (up to 24V) can also be used to trigger these inputs (i.e. track voltage, which is also the case when track switches are used).

By default (alterable by configuration variables), the first 7 inputs are programmed for shuttle train operations, switch ladder actuation or as "event inputs" for automatic operating sequences (AOS).

Regarding the allocation of shuttle train inputs: see MX31 manual; stop-over times during shuttle train operations: see CV's #41 – 56 in this manual. For definition and operation of AOS' see chapter "AOS – Automatic Operating Sequences", CV's #100, 101 below and the MX31 manual.

The eighth (last) input can be used (by default) for connecting a panic button that initiates an emergency stop of all locomotives when actuated. Any positive voltage can be used as input, i.e. the 5V from pin 1 or from the track.

Connecting track switches for shuttle train operation:

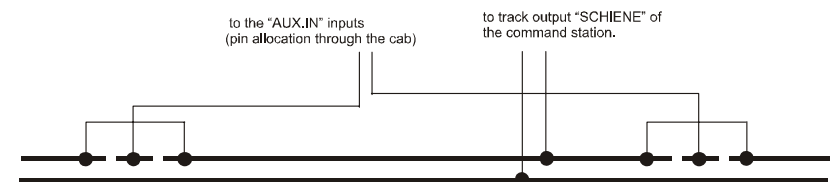

Example of an "event" switch for an automatic operating sequence (AOS):

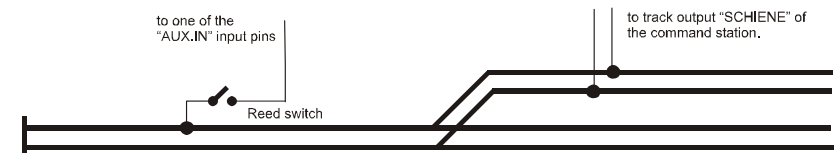

10. The CONTROL bus (booster connection)

The CONTROL bus establishes communication between the command station and boosters that is the command station sends information out through the "DCC-out" connector, which is reproduced by the boosters and receives information back from the boosters regarding over current conditions of booster units.

An NMRA standard exists for the CONTROL bus protocol (although not passed by the NMRA at the time this manual was written), which makes the use of third party products possible provided they adhere to this standard.

In case of a pure ZIMO configuration that connects a ZIMO command station with ZIMO boosters (a MX1HS may also be used as a booster if the appropriate jumpers are in the proper positions – see chapter 15), the information feedback is normally not transmitted via the CONTROL bus but preferably via the CAN wiring, because more information is accessible (e.g. about failed power districts). In this case the wiring is to be done according to the upper of the two following drawings:

A "booster number" must be set with the help of the DIP switches 1 - 5 of the **slave unit**; a different combination for each slave unit, therefore a maximum of 15 slaves.
The DCC, MOT and VAR switches must be OFF !
 MX1HS as slave: place **jumpers inside** in proper position (see chapter "MX1HS as Booster-Unit") !!

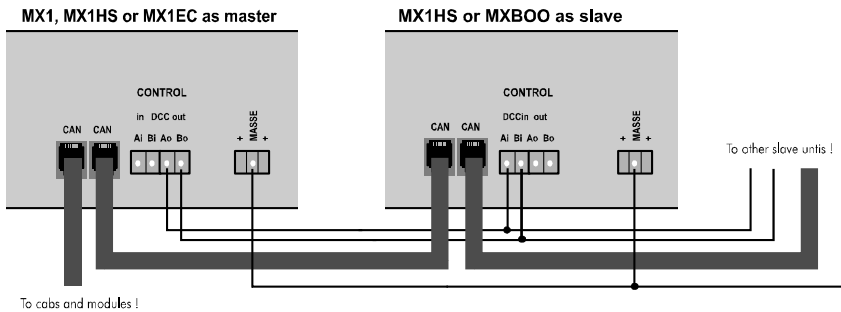

Only valid for MX1 and MX1HS (not for MX1EC):
 Connect DCC-in - (Ai) with DCC-out - (Ao) at the master unit !!

MX1 - DCC-out - A and B are connected with third party booster inputs
 MX1 - DCC-in - B is connected with the third party booster output

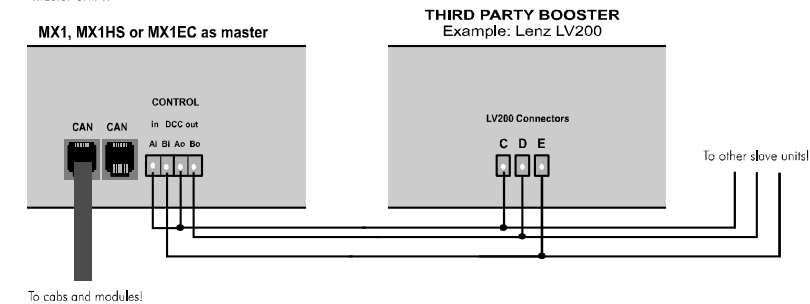

11. The Configuration Variables

The command stations offer the possibilities to modify certain characteristics by means of configuration variables. New features are introduced at the ZIMO web site www.zimo.at or can be studied in new editions of this manual.

How to program or read out configuration variables is covered in the chapters "Addressing and Programming" of the cab manuals (MX31...). The usual programming procedure is started by pressing the "E" key followed by the "MAN" key, "100" is used as the command station address.

CV	Name	Range	Default	Description
#5	Max. current on SCHIENE 1 (MAIN)	0 - 80 (= 0 - 8 A)	80 (= 8 A)	This CV defines the maximum allowable current for output "SCHIENE 1" (MAIN track) before the over-current protection is triggered that shuts the power off. (Default 80 = 8 A)
#6	Max. current on SCHIENE 2 = PROG	0 - 80 (= 0 - 8 A)	80 (= 8 A)	This CV defines the maximum allowable current for output "PROG" or "SCHIENE 2" (MAIN track) before the over-current protection is triggered that shuts the power off. (Default 30 = 3 A for MX1, 80 = 8 A for MX1HS)
#7	Switch-off delay SCHIENE 1 (MAIN)	0 - 254 (= 2 - 508 ms)	250 (= 0,5 s)	After an over current situation is recognized (i.e. short circuit) the command station switches to a "holding current" for the duration of the delay time, which means the track voltage is being reduced to limit current flow to 10A. After the delay time has elapsed, the output is shut-off completely (i.e. "UES"). With this procedure it is possible to bridge very brief short circuits that often occur at frogs without shutting the layout down. For some applications the default delay is too long (a "short" could leave burn marks on N-scale wheels) and it is recommended to lower the delay time if necessary.
#8	Switch-off delay SCHIENE 2	0 - 254 (= 2 - 508 ms)	250 (= 0,5 s)	Same as CV # 7, but for "SCHIENE 2" or "PROG" output. NOTE: The full range of adjustment in CV #8 is only effective for MX1HS; the delay time of the MX1 is always limited to 100ms (can only be varied between 0 and 100ms).
#9	Volt meter corrections SCHIENE 1	90 - 110	102	Larger CV value = smaller display value and vice a versa. (Adjusting range about 2 V).
#10	Volt meter corrections SCHIENE 2	90 - 110	102	Larger CV value = smaller display value and vice a versa. (Adjusting range about 2 V).
#11	DCC Timing = Length of „1-Bit“	146 - 162 microsec	158	The short DCC bits (value "1") can be modified in length deviating from the NMRA standards. Useful for some third party decoders.
#12	RS 232	1 - 6	4	= 1: 1200 bit/s

CV	Name	Range	Default	Description
	Bit rate	(= 1200 bit/s to 38400 bit/s)	(= 9600 bit/s)	= 2: 2400 bit/s = 3: 4800 bit/s = 4: 9600 bit/s = 5: 19200 bit/s = 6: 38400 bit/s
#13	RS 232 Handshake	0, 1	1	= 0: no Handshake = 1: RTS/CTS Handshake
#14	Number of preamble bits	10 - 30	26	Number of 1-bits (short bits) between the end of a DCC command and the first byte of the next command; synchronizes the serial data transmission in decoders. The default value (26) includes the special ZIMO ACK and interpacket bits (4 + 10 bits), which leaves 12 "real" preamble bits. If the ZIMO features "Signal controlled speed influence" and "loco number identification" is not used, the number of preamble bits can be reduced to 14 (the minimum number required according to NMRA RP's).
#15	Number of preamble bits in service mode	20 - 30	23	Number of preamble bits during service mode programming at the "PROG" output.
#19	Address for analog locomotive	1 - 127	0	The address entered here allows the control of an "analog locomotive" (without decoder) with the DCC cab. = 0: no analog locomotive can be controlled with the cab; this setting should always be retained if no analog locomotive is intended to be used (DCC signal is more efficient).
#20	Stop time <u>before</u> a direction change	0 - 255 (= 0 to 2 sec)	255 (= 2 sec)	These times are in effect when the direction key on the cab is pushed "on the fly", with the loco running (without moving the speed slider to 0 first). By default, the direction is changed (headlights switching) 2 seconds after the end of the stop time is reached (per cab settings, the decoder's CV #4 is not being considered) and after another 2 seconds the acceleration in the opposite direction starts.
#21	Stop time <u>after</u> a direction change	0 - 255 (= 0 to 2 sec)	255 (= 2 sec)	
#22	Time interval for turnout ladders	0 - 255 (= 0 to 2 sec)	70 (= 0,5 sec)	Turnout ladders are defined with the cab by "sample actuation" with addresses 700.1, 700.2 ... 799.7. When a turnout ladder so defined is actuated later, the time delay entered in CV #22 is applied between the single switch commands.
#23	Clearing priorities	1	0	Entering the value "1" clears all priorities in the DCC send cycle (same as with switch 5, see chapter "Controls...") CV #23 automatically resets to 0, so reading out this CV always returns a 0.
#24	HARD RESET and memory erase	0, 111, 222	0	This is a pseudo-programming (the value entered is not stored, always remains 0) = "222": HARD RESET, all CV's are set to default.

CV	Name	Range	Default	Description
	(from SW version 2.14)			= "111": Clears memory (as with switches, see page 7).
#25	Amp meter calibration "SCHIENE 1" (MAIN)	1 - 255	0	If the display deviates from 0 without a corresponding load on the track outputs, the display for each output can be reduced in 10mA steps. Values 255 to 128 stand for "-1" to "-127".
#26	"SCHIENE 2" (PROG)	1 - 255	0	
#27	"General switch-over" between 8-function and 12-function mode	0, 1	1	= 0: All loco decoders are set to the 8-function mode. = 1: ... to the 12-function mode.
#29	System state after power up	0, 1, 2	0	= 0: Normal operation = 1: Broadcast stop (SSP) = 2: Track power off (AUS)
#31 #32 #33 #34 #35 #36 #37 #38	„AUX.IN“- Input application ATTENTION: When an input is used in an AOS application the pertaining CV must be set to "0"!	0 - 5	0 0 0 0 0 0 2	#31 - #38 = "AUX. IN" – Inputs 1 - 8! = 0: Input not active (or AOS) = 1: Shuttle train operation (allocated with the cab) = 2: Panic button connected (initiates a broadcast stop) = 3: Panic button connected (turns track power off) = 4: Activates a turnout ladder = 5: Shuttle train operation and turnout ladder activation = 6: Push-button switch for programming lock release = 7: For "event"-unlock switch at AOS sample run
#41, 42 #43, 44 #45, 46 #47, 48 #49, 50 #51, 52 #53, 54 #55, 56	Stop time <u>before</u> or <u>after</u> a direction change during shuttle train operation.	1 - 255 (= 1 - 255 sec)	0, 0 0, 0 0, 0 0, 0 0, 0 0, 0 0, 0	2 CV's for each of the 8 "AUX. IN" – Inputs! These CV's take effect only if the relevant CV is set to automatic shuttle train operation (value 1 in CV's #31...38). One of the two CV's (e.g. #41) for stop times before and one CV (e.g. #42) for stop times after the automatic change of direction.
#57 #58 #59 #60 #61 #62 #63 #64	Activating of a turnout ladder with an external switch.	11 - 99	0 0 0 0 0 0 0 0	One CV for each of the 8 "AUX. IN" – Inputs, which only take effect if the input is set for turnout ladder activation (value 4 in the corresponding CV #31...38). Tens digit: Turnout ladder group address (1 - 9 = 701 – 709) Ones digit; Number key (1 – 9) that is defined as the turnout ladder actuation key on the cab.
#81	Initialization of priorities in the send cycle. for DCC-Addr < 127	0 - 9	7	All addresses are set to the priority specified in this CV after power up. = 1: Priority as before power-off = 2: Priority 3

CV	Name	Range	Default	Description
#82 #83	for DCC-Addr > 127 for MOTOROLA	0 - 9 0 - 9	7 7	= 3: Priority 4 = 4: Priority 5 (lowest priority) = 5: Priority 3 when speed > 0, otherwise 4 = 6: Priority 4 when speed > 0, otherwise 5 = 7: Priority 3 when speed > 0, otherwise 5 = 8: Addr.>127 removed from send cycle when speed = 0 = 9: Addr.>127 removed from send cycle
#84	Addresses remain in higher priority after deactivation from the cab	0, 1	0	= 0: Priority of addresses (> 127) that have been deleted from the cab for some time is lowered. = 1: Addresses remain permanently in priority 3 CV #84 = 1 is recommended for larger layouts. Disadvantage: addresses that were entered accidentally also remain in high priority and reduce the send cycle efficiency. Therefore erase priorities once in a while!
#91	Adapt programming procedure to third party decoder	0 - 3	0	= 0: Normal = 1/2/3: Turn track power off before, after or before + after the programming procedure.
#92	Broadcast stop initiated on main track while programming on the programming track.	0, 1	0	= 0: Broadcast stop (SSP) prevents unintended start up's in MX9 sections. New with SW-version 2.05! = 1: Trains on main track run unhindered during programming.
#93	Programming on the programming track: Maximum power	60 - 240	150	= 60: 100 mA = 150: 250 mA = 240: 400 mA Changing this CV may help programming / reading locomotives that always consume power (i.e. with sound modules).
#94	Acknowledgment power	10 - 20	30	= 10: 17 mA = 30: 50 mA = 120: 200 mA Changing this CV may improve the recognition of acknowledgment pulses and CV read-outs in "difficult cases".
#95 #96	Max. number of „ACK Wait“ packages „Reset Packages“ after programming start		15 30	Details during the programming process for the purpose of helping with "difficult" third party decoders. Number of "ACK Wait" packages at the start of the programming procedure, or the number of "Reset Packages" that are sent after the programming procedure.
#99	LGB pulse chain send		70	+/- 10 ms. Change this CV in case the functions on LGB engines don't work properly.
#100	Special-CV's AOS			See Chapter "Automatic Operating Sequences"!
#102	RailCom – cut-out (from SW-Version 3.03)	0, 1, 3	0	= 0: No RailCom cut-out = 1: Produces RailCom cut-out = 3 (only for MX1EC): RailCom cut-out and RailCom bridge

12. MX1HS as Booster-Unit

The high-output version MX1HS can also be used as a slave unit and operates identical to the “real” booster unit MXBOO.

In order to “convert” a MX1HS to a booster, jumper positions need to be changed inside:

After removing the top cover, the two jumpers just ahead of the 4-pin “CONTROL” connector become visible (see drawing below). Both jumpers are normally in the right position (MX1HS as command station).

When both jumpers are moved to the left position the MX1HS becomes a slave unit and is only usable as such. Furthermore, the switches DCC, MOT and VAR must be set to OFF and if several boosters are employed a booster number must also be set. See the chapter “The CONTROL bus” for connecting a booster (slave) with a master command station!

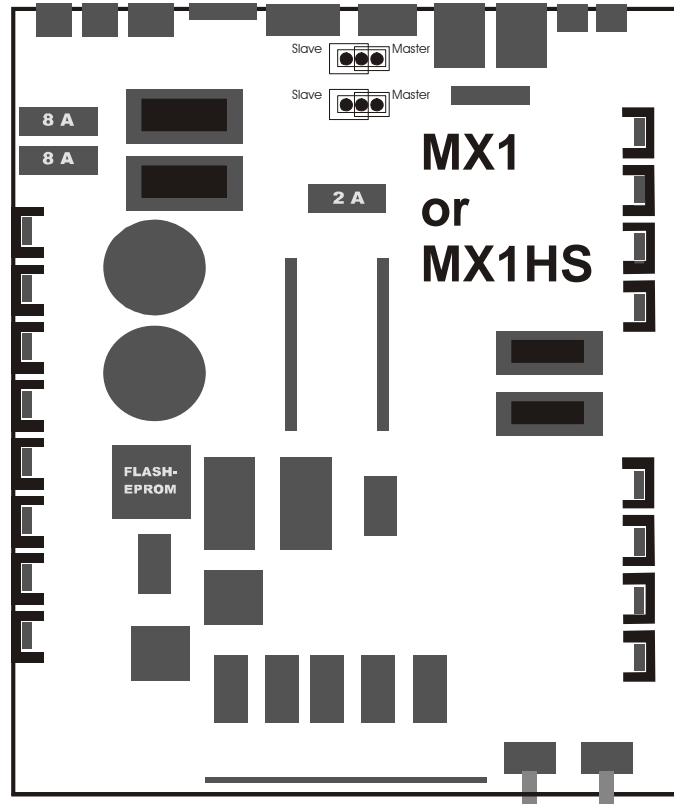

13. Fuses

2 Fuses (3 in the MX1HS) are accessible after removing the top cover; one (two in the MX1HS) of them are 8A fuses in the left rear close to the TRAFU input; the other (2A or 4A) in the center near the CAN bus outputs.

If an 8A fuse blows, the whole power supply to the command station itself and all connected modules is interrupted (nothing lights up...) or the second power district (on an MX1HS). In most cases the reason is a defect in the command station. A one-time replacement of the fuse can be tried.

A blown 2A (or 4A) fuse interrupts power to the CAN bus, which is noticed by the “dark” cabs. In most cases it is not due to a defective command station but rather a defective CAN bus cable (short between power and ground). Replace the fuse and locate the defective cable by swapping each one with a known good one, starting at the command station.

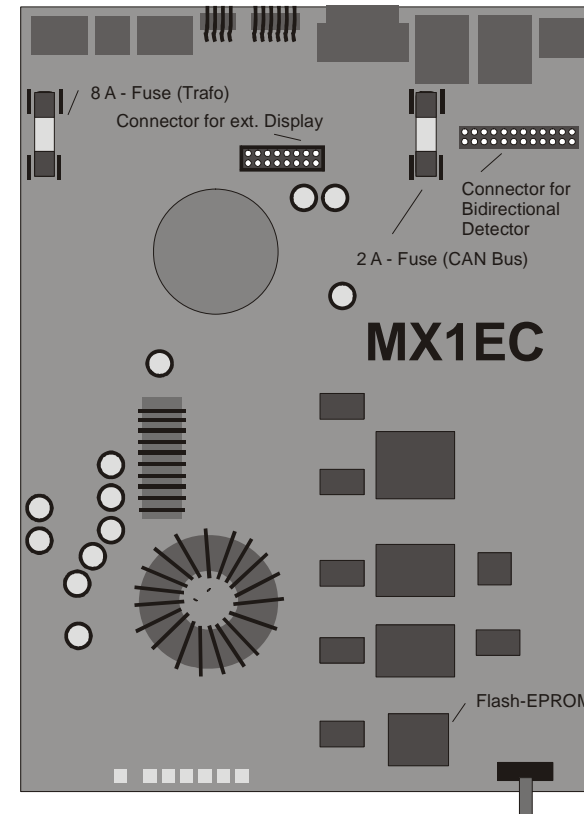

14. SOFTWARE Update

As is the case with most ZIMO components, the MX1 command station contains a micro processor for which software that controls all functions is stored in a FLASH-EPROM. The software is revised as required and made available to all users.

The software is preferably replaced with the help of a computer. Corresponding HEX files and an update program are available from the ZIMO web site: www.zimo.at See below regarding the program "ZST"!

If an update via computer is not possible or an update from a version older than 10 is required (version is displayed during power up), the FLASH-EPROM itself would have to be replaced (a new EEPROM is available from ZIMO).

To replace a FLASH-EPROM:

Remove the top cover only after the command station is powered down and the transformer unplugged.

The socket containing the FLASH-EPROM is located inside the command station on the left (MX1, MX1HS) or to the front (MX1EC). Carefully remove the FLASH-EPROM from its socket and push the new one all the way down. Be careful not to damage the socket or the solder joints!

15. The Program ZST (ZIMO Service Tool)

The software ZST has been available for download at no charge from the ZIMO web site www.zimp.at since September 2004. It is intended to facilitate the update process of command stations and all connected modules containing FLASH-EPROMS (MX21, MX31, MXFU...) and will continually be expanded (Equipment-CV programming, CAN bus monitoring, statistical evaluations, data back-up and more).

After pressing the button "Start with MX1 online" on the ZST entry page, the computer starts communication with the MX1 and reads/displays some information (current SW version, size of memory...).



The MX1 display confirms with: "ZST serial on".

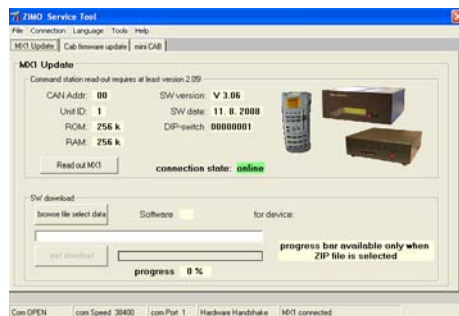
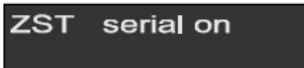

Click on "browse file select data" to select the zip-file that contains the new SW version, which was previously downloaded from the UPDATE pages of www.zimo.at. The installation of the new software is started by clicking on the button "start download". The installation progress is indicated by the progress bar.

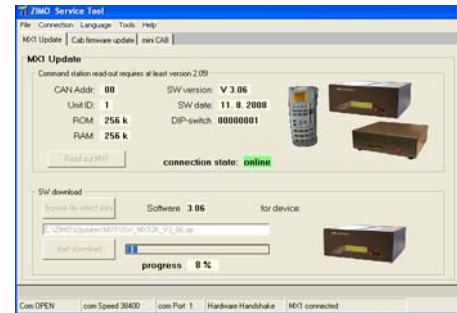

Please follow the notes accompanying the individual versions found on the UPDATE page at www.zimo.at.

For example: In many instances a **HARD RESET** is required after an update that also deletes the memory by programming CV #24 = 111 !

The MX1 display confirms with:



IMPORTANT, especially for 2007: "reanimate" command station.

Special cases: Software update with preceding **BOOT ROM update**

as is the case when updating from **SW version 2.x to 3.x** but also after a **failed update**:

In certain cases (i.e. when storage segments that have never been used before are being utilized in the command station) the BOOT ROM has to be replaced before the actual software can be updated. The BOOT ROM is responsible for the actual SW installation but it normally remains unchanged. To replace the BOOT ROM the "OFFLINE" button must be clicked on at the ZST start-up page; this prevents the computer from establishing communication with the command station even though a connection exists. Next, click on the button "browse file select data" and select the new BOOT ROM file (this file is also available from the ZIMO web site and has to be saved on your PC beforehand). A picture of a pair of boots is now shown as confirmation that the proper file has been selected.

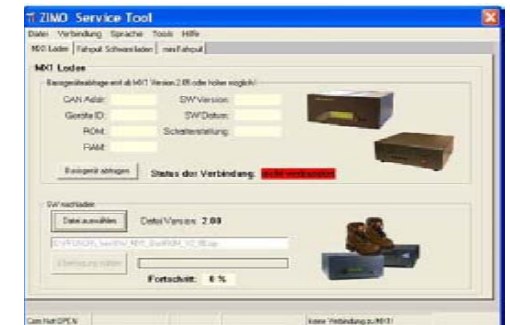

Now: turn the command station **OFF!!**

Click on the file tab in ZST and on "**reanimate MX1**". Confirm the COM port in the pop-up window (usually 1). Turn the command station back **ON**; the BOOT ROM installation should now start automatically and is confirmed in the command station display with "Download Flash", "BootRom xxx or „Warte auf Prog“.

... The actual software update can now be performed as described above ("browse file select data", "start download" ...).

16. AOS – Automatic Operating Sequences

From MX1, MX1HS, MX1EC SW-version 3.04 (corrected version of 2.05)!

What is an “Automatic Operating Sequence” (AOS)?

It is in principle a timed and most often continuous replay of previously recorded sequences of drive and switch commands.

In the course of a “sample run”, all commands sent by the cab to locomotives (speed, direction, functions) and accessories (turnout and signal positions) are being recorded and stored in the command station along with their relative time stamps. Additionally so-called **events**, which are signals from track switches, reed switches or similar are also recorded. Executing a stored operating sequence later plays back the recorded commands, where the recorded events are used for the necessary corrections in time (by comparing the actual events with the recorded events).

With “AOS”, shuttle train operations with stop times, signaling and sound effects even with two or more alternating trains are possible but also more complex processes like repetitive shunting movements.

Any number of locomotives and accessories may be part of a sequence. Each sequence is recorded separately; but several sequences can of course be played back simultaneously.

Recommendations to “event” triggers:

Track contacts, reed switches (with magnets on locomotives), photocells etc. can all be used as “event” triggers and connected to the “AUX.IN” inputs of the command station; see chapter 8.

In many cases one single “event” in the sequence is sufficient. With the track configuration shown below for example, an alternating shuttle service of two trains can be defined, that is, from each of the two dead-end sections to the right a train should move to the end of the common track (far left), stop, and return to its own track. The track contact in the common section is the “event” input and allows for automatic time-modifications to the sequence (increase or decrease) in order to compensate for changes in driving behavior (warm-up etc.).

Alternative example of an “event” trigger location for an operating sequence (AOS):

(track contacts shown but reed switches would also be possible)

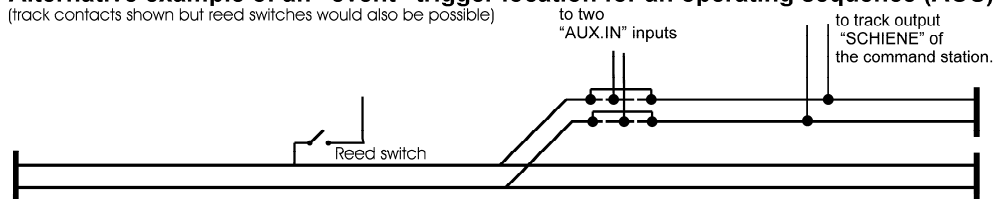

Example of an “event” trigger location for an operating sequence (AOS):

(With reed switch, but track contact would also be possible)

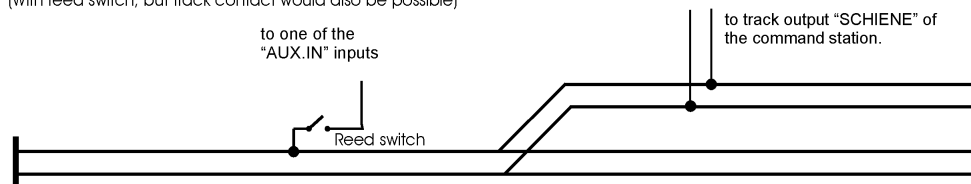

IMPORTANT RULES when several event triggers are on the same AOS section:

- **Events must not overlap**; for example: it must not happen that the head of the train triggers the second event and the end of the train the first event again.
- **Events must not overtake each other** (only relevant when two trains are running at the same time); for example: it is not permissible that two consecutive events, triggered by two trains, are timed so close to each other that the sequence during playback may reverse itself.

Recording an operating sequence by means of a sample run:

Described here using a MX2, MX21 or MX31 cab.

The MX2 (MX21, MX31...) uses the definition procedure for turnout ladders for this, particularly the special group addresses range between 790 and 799.

The memory location of an operating sequence is determined by the group address (AOS – group) 790....799 and the location number 1...8 of each group.

For both, recording and executing an operating sequence, the group address is first entered in the cab just like a loco address but activated with the “A” key (for a module address). The cab then indicates with the LED above each number key 1 – 8 whether the locations concerned are still free or already occupied:

Key-LED green: Location is empty (ready for a new recording)

Key-LED yellow: Location is full (a new recording is only possible after deleting the old)

All key-LED's flashing red: Memory full (no further definitions are possible)

To delete a memory location press the “C” key together with the corresponding location key.

To start recording a sample run, press the desired location key (1....8) for at least 1 second; which the cab confirms with the

Key-LED flashing red/green: Recording of a sample run in progress.

Before starting with the sample run, bring the locomotive(s) and accessories to their start position, activate them on one or several cabs or make sure they are easy accessible (in recall memory); to facilitate the whole process it is recommended that another cab is used (or several cabs) than the one the AOS group (709....799) was initiated with.

IMPORTANT: Since all cab commands are being recorded during a sample run, abstain from running other trains or operating other accessories; furthermore all MX8 and MX9 modules should be disconnected from the CAN bus (otherwise their function would be disturbed during an AOS execution later)! The layout itself however may remain connected.

After the recording has started (when the key-LED flashes red/green), all cab activities are being recorded and the sample run may begin. All train movements, loco functions, turnout and signal actuations must now be made exactly the way they should later be operated when the AOS is played back endlessly.

At the end of the sample run, all locos should be back to their starting point; otherwise there will be no endless replay possible. The recording is ended by pressing the same location key briefly (the key with the LED flashing red/green). The indicator then changes to

Key-LED yellow: memory location is full,

if the recording was successful. If the key-LED turns green, the recording was not possible. If during or at the end of a recording the

Key-LED flashes red: the memory has been exhausted (no recording takes place).

AOS-specific information displayed by the command station:



Useful information is shown on the MX1 display during a sample run; the recording itself does however not depend on the display, that is it is also possible with a MX1EC that doesn't have a display.

As soon as an AOS procedure is entered (input and activation of a group address on the cab), the upper line displays statistical data of the AOS memory: the number of already stored sequences and the occupied/free memory space.

Note: The displayed occupancy rate in percent relates to maximum available space reserved for AOS of the currently installed software version. This value can change without the operators input (without deleting or adding of sequences); by updating the command station with new software or if the memory is used for other tasks (i.e. storing of loco names).

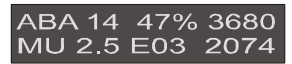

The lower line is active during a sample run; that is after the recording was started by pressing the appropriate number key for at least one second.

This is especially useful to confirm whether the expected "events" (triggers) are coming and how much memory is being used up for this sequence.

The display also shows deleting actions and other procedures (lower line); as well as error messages:



Error #2: Memory for playback administration is full *)
Error #3: Memory is full

*) can be freed by deleting sequences.

IMPORTANT Lock and unlock events:

A possible problem during a sample run may be that the contact section, Reed switch or similar is triggered several times by the same train (by wheels, field magnets of motors etc.). These multiple triggers must not be recorded since they won't necessarily be played back every time (sometimes just coincidental). The train should cause only **one single event** regardless of the number of triggers: therefore multiple triggers are **blocked** automatically after the first trigger is received.

Such "event locks" must of course be unlocked again in order to continue with the recording, which is done as follows:

- (automatically) by the next event along the route,
- (automatically) by a change in direction, or
- (manual) by means of a special "event unlock switch".

With most operating sequences, especially in the form of shuttle train operations, the "automatic unlock" through another event or by a change in direction is sufficient to ensure that all events are unlocked before they are needed again. Not so in a circular layout with just one event switch that is triggered always in the same direction. This would permanently lock that event. For such cases the manual "event unlock switch" is to be actuated during a sample run, after the train completely passed over the event trigger. A push-button switch that serves as the "event unlock switch" can be connected to any one of the unused "AUX.IN" inputs on the command station and defined for this purpose by programming the corresponding CV (#31 – 38) to "7".

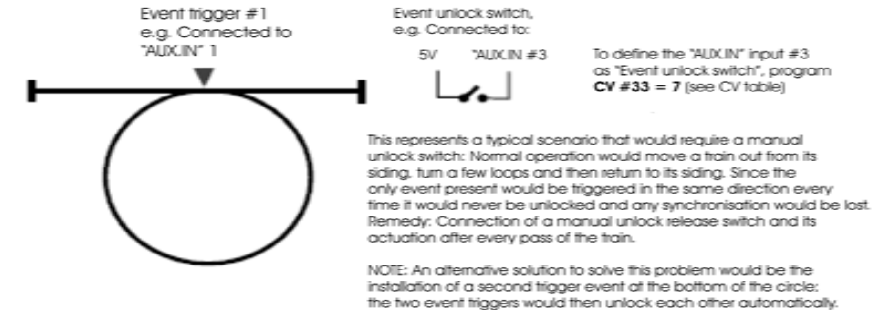
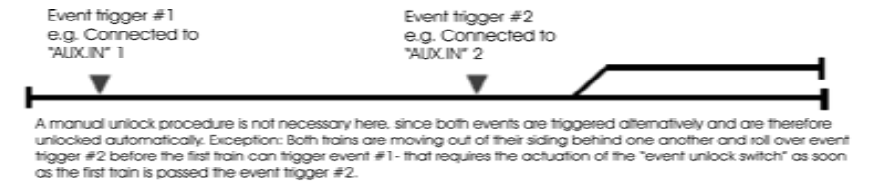

NOTE: An alternative solution to solve this problem would be the installation of a second trigger event at the bottom of the circle: the two event triggers would then unlock each other automatically.

Only important in rare occasions: When a train changes direction and triggers an event...

When a train or locomotive comes to a stop while triggering an event (i.e. with one or several conductive axles) and then starts up in the opposite direction, an undesired event may be triggered in the start-up direction because the first event was unlocked due to the direction change. If this becomes a problem, CV #101 Bit 1 can be used to prevent the event from unlocking after just one change in direction!

Executing a stored operating sequence:

Described here using a MX2, MX21 or MX31 cab.

The playback is started the same way as a sample run recording, by entering the group address on the cab as you would for a loco address but accepting it with the "A" key instead. The LED's above each number key (1...8) indicate whether the memory locations are empty or occupied:

- Key-LED green: memory location is empty
 - Key-LED yellow: memory location holds a sequence (playback activation is possible)
- To playback a stored operating sequence, press the key of the desired "yellow" memory location **briefly**; which is acknowledged by
- Key-LED flashing yellow: operating sequence is running.

Before the operating sequence can be played back, the locomotives involved must be at their respective starting positions, as they were at the start of the sample run (recording).

Any cabs showing an active loco address that is part of this sequence will have that address automatically deactivated (address is flashing).

ATTENTION: Loco addresses that are part of an operating sequence must not be activated with the cab while the sequence is being played back!!

To end a playback, press the same key **once briefly**; which is acknowledged by

Key-LED-flashing red: all trains that are part of this sequence are being returned to their starting location and automatically stopped.

Or press they key **twice**; which is acknowledged by

Key-LED yellow: memory location holds a sequence but is no longer in playback mode.

AOS-specific information displayed by the command station:

Depending on the CV #101 setting (see below), useful information during playback of an operating sequence is shown by the MX1 display either temporarily (about 20 sec, default) or permanently (CV #101, Bit 0 =1).

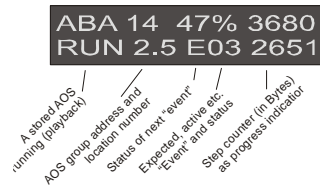

The upper line shows common data about the AOS memory (as during a recording); the lower line is all about the “event” handling: it shows whether the timing during playback matches the sample run and whether the “events” are being recognized properly. For this purpose, the “events” are shown with prefixes:

N... = This is the next expected “event”; the playback of stored commands is being executed as planned (that is according to the recorded time stamps).

W...= The “event” is imminent that is no more commands are to be executed ahead of this “event”. If the train is late (compared to the sample run), the playback is delayed until the “event” is triggered in order to re-synchronize the sequence.

S... = The “event” was triggered earlier than expected (the train was faster than during the sample run); the playback speed is increased to re-synchronize the sequence; that is the commands are processed faster.

B...= The next “event” is locked because it is also the past “event”, and multiple triggers by axles of the train are expected (see “IMPORTANT...” on the previous page).

E... = “Event” is being triggered.

X00 = This operating sequence contains no “events” (no synchronization possible).

MX1 – Configuration variables for Automatic Operating Sequences (AOS):

These parameters are absolutely valid for MX2 and MX21 cabs; with an MX31 cab and future software version an individual setting for every operating sequence is possible. See MX31 manual!

CV #100: Simulation of overdue “events”. In case a stored “event” has not been triggered, the sequence is aborted after 1 minute by default (CV #100 = 0); most often though an accident will happen before the 1 minute has elapsed (collision at the end of the run or similar). With

CV #100, Bits 0 – 5 = 0...63 a time is defined after which a reaction takes place if an “event” is overdue, namely

when Bit 7, 6 = 00 the operating sequence is being aborted;

when Bit 7, 6 = 01 (decimal + 64) the “event” is being simulated.

For example: If CV #100 = 69, the overdue “event” (compared to the recorded “event”) is generated artificially after 5 seconds and the operating sequence will continue.

CV #101: pertains to the accompanying information displayed by the MX1 when executing a stored operating sequence; by default the information is displayed only briefly and thereafter switches back to the normal MX1 volt and amp meter display. This does not affect the display during a sample run recording, which is always displayed permanently:

Bit 0 = 0: Display is used “normally” (Volt and amp meter ...), not for AOS

Bit 0 = 1: The last activated sequence is continuously being displayed and updated.

Bit 1 = 0: Unlock after next event triggered or with change in direction (or unlock switch)

Bit 1 = 1: Unlock after next event triggered and change in direction or after two triggered events (or unlock switch)

17. The “old” (ASCII-oriented) Interface

This section is only of interest to users that want to operate the layout with an external computer but don’t want to use the ready made software “STP”.

The serial interface of the MX1 command station allows the control of trains and accessories by a computer as well as the polling of current route and switch data from the computer.

The interface at the MX1 is a 9-pin Sub-D socket; the connection with a computer is done with a 1:1 serial cable.

The following described protocol was adopted from the previous product of the MX1 “model 2000” command station described here and ensures compatibility to already existing applications. A more powerful (alternative) protocol is in preparation (binary instead of ASCII).

Data transmission parameters:

9600 bit /s (default) - 8 bit - no parity - number of stop-bits 1 or 2. (higher speed selectable with CV #12).

Computer to MX1 command format:

COMMAND ID - INFORMATION BYTES - CARRIAGE RETURN
(defines the command) (command data) (always last byte of a command)

The COMMAND ID is an ASCII letter (i.e. S, F, K etc.), which identifies the kind of command and also determines the meaning of the information byte that follows.

With the command ID “S” only one INFORMATION BYTE follows in the form of another ASCII letter (S, A, E).

All other command ID’s can be followed by a row of INFORMATION BYTES, which are however not coded as binary but rather as two ASCII characters that represent the hexadecimal value (function “HEX\$” in BASIC).

At the end of each command, a CARRIAGE RETURN code must be present (“CHR\$(13)” in BASIC).

Example of opening the interface and sending a loco command in BASIC:

```
OPEN "COM1:9600,N,8,1,CS,DS,CD" FOR OUTPUT AS #2
PRINT#2, "F"; "N"; HEX$(Loco address); HEX$(Speed step);
HEX$(Data byte1); HEX$(Data byte1); CHR$(13);
```

“F” is the command ID for loco commands; “Loco address” and “Data byte” are in decimal form (i.e. loco address = 123, the data byte is a combination of speed and functions, see below); CHR\$(13) is the concluding carriage return.

ATTENTION: A leading “0” must be entered with values of <16!

All information bytes (loco address, speed step, data bytes etc. as described in the following commands) must be sent to the MX1 command station in the form of two ASCII characters. The “HEX\$” function however sends in many BASIC versions only one character for values smaller than 16 (hexadecimal characters “0” to “F”). A “0” must be added as a leading character in such cases; if possible with corresponding BASIC commands or by defining a special function that always produces two characters.

Note for the creation of commands in other than a BASIC environment:

Sending the respective command ID (ASCII) does not present a problem. Coding of information bytes is as follows: a loco address of "123" for example corresponds to the hexadecimal figure "7B", which is being sent as the two ASCII characters "7" and "B" (only capital letters are allowed as hexadecimal characters!). The same applies to data bytes: for example, the "L function ON" and the speed step 14 in a loco command result in a hexadecimal figures "1" and "E", which are send as ASCII characters. ATTENTION: always two ASCII characters per information byte (add a leading zero if necessary).

Description of individual command types:

NOTE: In case of a MX1 command station sending out several data formats (DCC, MOTOROLA), the respective loco or accessory address must contain a data format prefix:

"N" for DCC (for ZIMO and other NMRA-DCC compatible decoders) / "M" for MOTOROLA (Märklin decoder).

Broadcast stop and track power OFF/ON commands: Command ID "S"

The entire command consists of only the command ID "S" and another letter, which represents its content, as well as the obligatory carriage return:

"SS"; CHR\$(13) - Broadcast stop ON (stops all trains).

"SA"; CHR\$(13) - Track power OFF.

"SE"; CHR\$(13) - Track power and broadcast stop OFF (normal operation commences).

Loco command: Command ID "F"

Besides the command ID "F", the loco command consists of the appropriate loco address and the data bytes, which contain the information about speed, direction and functions.

"F"; data format prefix ("N","M") HEX\$(loco address);
 HEX\$(speed step); HEX\$(data byte 1), HEX\$(data byte 2),
 HEX\$(data byte 3), CHR\$(13)

Data format prefix-	only "N", "M" allowed, see note above.
Loco address -	decimal value (1 to 255); use HEX\$(0) with single digit values
Speed step -	Speed step of the currently active speed step systems
Data byte 1 -	Bit 7 MAN-Bit
	Bit 6
	Bit 5 Direction (0 = forward, 1 = reverse)
	Bit 4 Headlights ON/OFF (= DCC-Function 0)
	Bit 3/2 DCC – speed step system
	(01 = 14 speed steps, 10 = 28 steps, 11 = 127 steps;
	Bit 1 Deceleration time "BZ" (definable with command "B") ON/OFF
	Bit 0 Acceleration time "AZ" (definable with command "A") ON/OFF
Data byte 2 -	Bit 0-7 Functions 1-8 ON/OFF
Data byte 3 -	Bit 0-3 Functions 9-12 ON/OFF

How the decimal value of the data byte that is entered to the above HEX\$-function is calculated, explains this example: "MAN" turned OFF, lights ON, direction reverse, speed step system "0-28", "AZ" and "BZ" OFF results in the binary word "00111000", which in turn is the equivalent to the decimal value of $0 \times 128 + 0 \times 64 + 1 \times 32 + 1 \times 16 + 1 \times 8 + 0 \times 4 + 0 \times 2 + 0 \times 1 = 56$.

Function inversion command: Command ID "U"

This command allows inversion of direction and/or function outputs; this is sometimes useful in computer applications.

"U"; Address prefix, HEX\$(loco address); HEX\$(data byte 1); HEX\$(data byte 2); CHR\$(13)

Data format prefix - only "N" and "M" or "Z" are allowed

Loco address - decimal value (1 to 255),

Data byte 1 - bit assignment like command "F", inversion with "1" (except 3/2)

Data byte 2 - bit assignment like command "F", in version with "1"

Data byte 3 - bit assignment like command "F", in version with "1"

Acceleration/deceleration (AZ/BZ) - command: Command ID "B"

Adjustment of "AZ" and "BZ", which are the acceleration and deceleration times controlled by the MX1 command station. Not to be confused with the configuration variables # 3 and # 4 in the decoders! "AZ" and "BZ" is independent of these configuration variables and it can also be used for non-DCC decoders. Note that "AZ" and "BZ" is turned ON and OFF with the "U" command.

"B"; data format prefix; HEX\$(loco address); HEX\$(data byte); CHR\$(13)

Data format prefix - only "N" and "M" or "Z" are allowed, see note above.

Loco address - decimal value (1 to 255)

Data byte - Bit 0-3 BZ (0 - 15)
 Bit 4-7 AZ (0 - 15)

Shuttle train command: Command ID "P"

This command allocates particular locomotives to the shuttle train inputs 1 to 4 of the command station (see the cab operating manual for details on shuttle train operations).

"P"; data format prefix; HEX\$(loco address); HEX\$(data byte); CHR\$(13)

Data format prefix - only "N" and "M" or "Z" are allowed, see note above.

Loco address - decimal value (1 to 255)

Data byte - Bit 0-3 Shuttle train inputs 1-4, forward
 Bit 4-7 Shuttle train inputs 1-4, reverse

Query of extend address indexing Command ID "E"

Locos with extended addresses (128 - 10239) are accessed with the usual commands listed above, but instead of the address itself, an automatically assigned internal index address (128 - 255) is used; which first needs to be ascertained with the help of the "E" query:

"E"; HEX\$(High-byte of the loco address); HEX\$(Low-byte); CHR\$(13)

The command station then supplies an index message; such a message is delivered for addresses >128 after each loco command to validate their assignment (unused loco addresses can lose their initial index address if required).

Commands for accessory DECODERS:

Command ID "M"

An accessory command is similar in its structure as a loco command; the data byte contains the actuation information of 4 (in the DCC and MOTOROLA format) or 8 (in the ZIMO data format) turnouts or signals.

"M"; data format prefix; HEX\$(Accessory decoder address); HEX\$(Data byte); CHR\$(13)

Data format prefix - only "N" and "M" or "Z" are allowed
 Accessory decoder address - decimal value (0 to 255); for MOTOROLA only to 63.
 Data byte (DCC-data format) Bit 7 9. Address bit (Address range 0 to 510 !)
 (The same for MOTOROLA- Bit 3 Switches ON or OFF (1=ON, 0=OFF)
 format but without Bit 7) Bit 2-0 Number of the output to be switched

NOTE: If a switch command cannot be executed because another accessory command is currently being processed, the MX1 answers with

"???"; CHR\$(13)

The switch command must be repeated (in intervals of about 500 msec) until the negative answer is no longer returned.

Commands for accessory MODULES:

Command ID "N"

In contrast to the loco and accessory DECODER's, the switch commands here are combined with the command ID "N". There are therefore two implementations of the command, depending on the "switch type".

"N"; HEX\$(Module address); HEX\$(Data byte); CHR\$(13)

Module address - 800 to 863
 Data byte as command - Bit 0-5 Number of the MX8 output
 Bit 6 Position (0 = left, 1 = right)
 Bit 7 = 1 (ID for command byte)
 Data byte for query Bit 0-7 = 0 (ID for query)

Status query:

Command ID "Z"

The command station is queried about the track voltage, broadcast stop and the available data formats (DCC, MOTOROLA, ZIMO).

"Z"; CHR\$(13)

Query the command station memory:

Command ID "A"

With this command the command station delivers information about current loco and accessory data for a specific locomotive or accessory address.

"A"; F/W selection; Data format prefix; HEX\$(Loco or accessory address); CHR\$(13)

F/W selection - "F" = Loco address, "W" = Accessory address
 Accessory address - if the DCC data format is used, a second data byte must be sent, of which only Bit 7 as the highest DCC address is being evaluated (address range up to 510).

Commands in conjunction with routes:

Command ID "W"

These commands relate to routes (turnout ladders) that are defined and called up with the cab (see cab manual). These route definitions are stored in the MX1 command station; the route memory can be read out, re-installed or deleted via the MX1 computer interface. This allows the route definitions to be saved in an external computer and if needed to be restored again (i.e. after loss of the MX1 memory or for transfer to another command station).

"WCLEAR"; CHR\$(13) - Delete all routes.

"WO"; CHR\$(13) - Send all stored route definitions to the computer.

"WI"; CHR\$(13) - Reload routes from the computer.

If the data structure of the "WI" command is known (will be added later), it will be possible to define routes in the computer and send them to the command station.

Commands in conjunction with lines:

Command ID "O"

These commands relate to lines (block control) that are defined and called up with the cab (see cab manual). These line definitions are stored in the MX1 command station; the memory can be read out, re-installed or deleted via the MX1 computer interface. This allows the line definitions to be saved in an external computer and if needed to be restored again (i.e. after loss of the MX1 memory or for transfer to another command station).

"OCLEAR"; CHR\$(13) - Delete all lines.

"OO"; CHR\$(13) - Send all stored line definitions to the computer.

""; CHR\$(13) - Reload lines from the computer.

If the data structure of the "" command is known (will be added later), it will be possible to define lines in the computer and send them to the command station.

Register-Programming

Command ID "R"

For addressing and CV programming of all NMRA-DCC compatible loco decoders (ZIMO and others) and for programmable decoders with the MOTOROLA format (Uhlenbrock decoder); the address is stored in configuration variable (register) 1. The programming is performed on the programming track.

"R"; Data format prefix ("N" or "M"); HEX\$(Register number); HEX\$(new value); CHR\$(13)

"RE" - Terminating the programming mode

The "R" command (same as the "Q") triggers a register message that serves as acknowledgment!

Register polling (for DCC data format only!)

Command ID "Q"

This command prompts the command station to send a register message, which is used for reading out configuration variables of NMRA-DCC compatible loco decoders.

"Q"; HEX\$(Register number); CHR\$(13)

Programming-on-the-main (for DCC data format only!)

Command ID "L"

"Programming on-the-fly" (or "programming-on-the-main").

"L"; HEX\$(Loco address); HEX\$(Command bytes); NMRA-Instruction; CHR\$(13)

Loco address - decimal value (1 to 127)
 Data byte - Bit 0-2 Number of bytes of the NMRA telegram (excl. ECC)
 Bit 3-5 Number of desired telegrams
 Bit 7 = 1: Address is locked out of the normal send cycle.
 = 0: Address is controlled normally after the desired number of telegrams have been sent.

NMRA-Instruction (up to 5 Bytes) - "On-the-main" – Command according to NMRA - RP 9.2.1

Special command:

Laa00 unlocks address aa without sending new data.

Message formats from MX1 to computer:

Command station status ("Z" query):

"Z"; HEX\$(status byte); CHR\$(13)

Status byte -Bit 7 MX1-Generation (0 = "old", 1 = "new")
 Bit 6 1 = ZIMO-Data format active (Type and jumper)
 Bit 5 1 = DCC- Data format active (Type and jumper)
 Bit 4 1 = MOTOROLA- Data format active (Type and jumper)
 Bit 0 Broadcast stop (1 = ON, 0 = OFF)
 Bit 1 Track power (1 = ON, 0 = OFF)
 Bit 2 UES-Short circuit protection (1 = ON, 0 = UES OFF)

Memory report (after "A" query):

"A"; F/W-Selection; data format prefix; HEX\$(Loco or accessory address);
 HEX\$(speed step); HEX\$(Data byte 1); HEX\$(Data byte 2);
 HEX\$(Data byte 3); HEX\$(AZ/BZ); HEX\$(Group byte); CHR\$(13)

F/W-Selection "F" = Loco address, "W" = Accessory address
 Data format prefix - only "N", "M" allowed
 F...- or M...addresses decimal value (1 to 255);
 additional Byte for DCC data format with
 Bit 7: 9. address byte; Bit 0: 0 = paired bits, 1 = single bits)
 Speed step or accessory position – as in "F" or "M" command
 Data byte 1 - Format same as data byte 1 in "F" command
 Data byte 2 - Format same as data byte 2 in "F" command
 AZ/BZ-Values - Format same as data byte in "B" command
 Data byte 1 - Bit allocation same as in "F" command

Data byte 2 - Bit allocation same as in "F" command
 Data byte 3 - Bit allocation same as in "F" command
 or
 Group byte -Bit 0 Cab activity (0 = not active, 1 = active, address in display)
 Bit 2 Loco decoder feedback (1 = received)

Register report (after "Q" query):

"Q", HEX\$(Error code), HEX\$(Register number); HEX\$(current value); CHR\$(13)
 Error code - 0 = successful read-out of register number

Index report (after "E" query or loco command for extended address):

"E", HEX\$(Index addressee), HEX\$(loco address high byte); HEX\$(low byte); CHR\$(13)
 Error code - 1 = "Old" ZIMO data format is active (jumper).
 3 = Address is < 128 (not extended address)
 5 = Index address is not assigned to a loco address.
 Error messages in form of an index address (Index address < 128 is an error message!).
 0 = no data block available.
 1 = "Old" ZIMO data format is active (Jumper).
 3 = Address is < 128 (must be used as normal address).

18. The "new" binary Interface Protocol

The binary protocol is available with SW versions 3.xx (2007). Its main purpose is to work together with software products like "TrainController" from Railroad&Co, but can of course also be used with other software.

Note: The "ZIMO geared" layout programs STP and ESTWGJ don't use this protocol because they are connected directly to the CAN bus, instead of the RS-232 interface.

Description of the binary protocol 3 is covered in a separate document and can be downloaded from the "manuals" pages at www.zimo.at !